



Saturn 24V OIL RACK

GEAR RACK MOTOR FOR **CONDOMINIUM USE FOR SLIDING GATES**
UP TO 1500 KG / 3300 LBS MAX WEIGHT



- Solid, die-cast aluminum body
- High quality mechanical limit switches
- Micro-switch for stop function on release lever in case of assistance
- Optional emergency batteries for operation in case of power failure
- Gears housed in a single piece cast aluminum block
- Emergency batteries and solar panel KIT SUNNY in option
- Electronic clutch as an extra anti-crush safety device.
- Reversing system in case of obstruction
- Release system with aluminium lever protected by lock
- **FAST model:** can be set on different speeds up to 1 1/2 feet/sec
- Duty Cycles*: 60 %

* Duty Cycles depend on gate size and installation



Release with aluminium lever and lock



SATURN OIL versions with oil lubrication of the gears for max duration



Mechanical twin-disc clutch

| CODE | DESCRIPTION | MAX LEAF WEIGHT | MAX LEAF LENGTH | DUTY CYCLES % | PCS FOR PALLETS |
|--------------|---------------------|-----------------|-----------------|---------------|-----------------|
| 12400285-CSA | SATURN 24V OIL RACK | 3300 lbs | 40 feet | 60 | 30 |

CONTROL BOARDS

| CODE | DESCRIPTION |
|---------------|---------------------------------------------|
| 2300A24U1MDGR | USER 1 - 24V DG MAXI Replace (only circuit) |

ACCESSORIES



23101104
ESUN Q
Battery charger 800 mA with solar panel admin



23106430 *
Kit SUPER SUNNY 85W
85W solar panel + charger +battery 33Ah



16700047
G-LOCK
Magnetic Lock

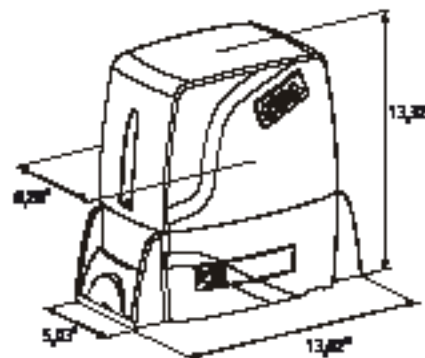

Dimensions (inches)



OIL-E
OIL
Yellow oil in 1 quart bottle



23106305
BAT7
Batteries with box (7AH)



12715010
RACKZ
Metal rack 3.28 ft



16101047
PZ20
Pinion Z20 mod. 4 for SATURN

PACKAGE SATURN 24VOIL RACK

- N.1 Operator SATURN 24V OIL RACK with 24V control board USER 1 24V DG
- N.1 Installation accessories Kit
- N.1 Installation instructions and general notice
- N.1 Foundation plate
- N.1 Warning signboard



NB: ESUN Q 23101104 to combine with BAT7 23106305
(* Plastic box not included)